

**Ferrite Magnet Die-cast Chassis Driver**



**Features**

- 4.5" Very Large Format Voice Coil
- 6800 Watts Peak Power Handling
- Active Balanced Cooling
- Ferrite Magnetics
- Square Wire Inside/Outside Coil Design
- Double Spider Suspension
- Integrated Demodulation Rings
- Die Cast Aluminum Chassis

**Applications**

The SD15-1700EL is a high output wide bandwidth transducer. The 15 inch (381mm) diameter piston will produce extremely high sound pressure levels at both low and mid band frequencies and is ideal for high level low frequency response in two and three way systems. This design is an excellent component for both live sound and recorded music venues. The transducer uses high energy ferrite magnetics to achieve a very high acoustic output to weight ratio. The SD15-1700EL has been optimized for use in two and three way sound reinforcement system designs. The operating bandwidth is 55Hz to 2000Hz.

The SD15-1700EL employs a very large 4.5 inch (114.3mm) diameter voice coil that provides an AES rated 1700 watts of continuous power handling and a full 6800 watts of peak rated power handling when sufficient amplifier headroom is available. The SD15-1700EL utilizes P Audio's Auto Balanced-Cooling (ABC) technology to not only improve transducer power handling and reliability but to also increase power compression performance by carefully balancing and directing airflow to critical areas.

The voice coil design is an "inside/outside" geometry with P Audio's square wire technology to improve conversion efficiency and provide a very large cross-sectional area for superior cooling.

System linearity is achieved by employing magnetic flux demodulation devices in the structure to increase fidelity and sonic accuracy. The system suspension has been designed specifically for high linear displacement and extended low frequency response and high level output in multi-way system designs. The double spider design insures very high displacement and linear response while maintaining excellent control

The transducer chassis is a die cast aluminum design that insures a very high degree of structural integrity.

**Specifications**

**General Specifications**

Nominal diameter.....	381 mm/15 in
Power rating.....	1700 W(AES)
Nominal impedance.....	8Ω
Sensitivity.....	96 dB
Frequency range.....	55-2000 Hz
Chassis type.....	Cast aluminum
Magnet type.....	Ferrite
Magnet weight.....	3.17 kg/111.8 oz
Voice coil diameter.....	114.3 mm/4.5 in
Coil material.....	SV-SQ
Former material.....	Glass fiber
Cone material.....	Paper
Surround material.....	Cloth
Suspension.....	Double
X-max.....	4.8 mm/0.19 in
Gap depth.....	15.0 mm/0.59 in
Voice coil winding width.....	24.7 mm/0.97 in
Net Weight.....	13.4 kg/29.5 lb
Packing Dimension WxDxH (mm)	430mm x 430mm x 240mm
Shipping Weight.....	14.8 kg/32.6 lb

**Small Signal Parameters**

Re.....	5.2Ω
Fs.....	50 Hz
Mms.....	158.8 g/5.60 oz
Mmd.....	114.4 g/4.03 oz
Qms.....	7.78
Qes.....	0.48
Qts.....	0.45
Vas.....	66.18 lt/2.34 ft³
Bl.....	23.34 Tm
Cms.....	6.5e-05 m/N
Rms.....	6.41 Ns/m
Le (at 1kHz).....	0.84 mH

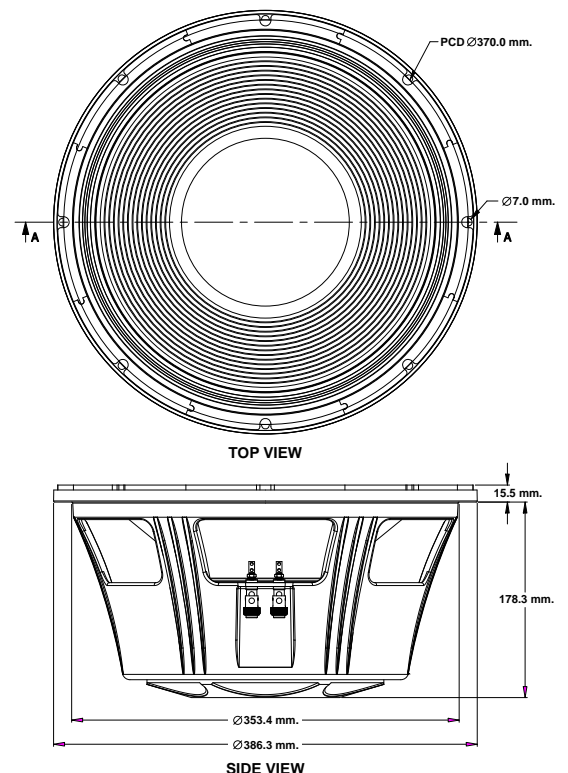

**Frequency Response and Impedance Curves**

